

PRODUCT INFORMATION PACKET

marathon[®]
Motors

Model No: 056T17WD15330
Catalog No: N433A
1,1800,TEFC,56C,3/60/208-230/460
Washdown Duty



Regal and Marathon are trademarks of Regal Beloit Corporation or one of its affiliated companies.
©2018 Regal Beloit Corporation, All Rights Reserved. MC017097E

REGAL[®]



Nameplate Specifications

Output HP	1 Hp	Output KW	0.75 kW
Frequency	60 Hz	Voltage	208-230/460 V
Current	3.2-3.0/1.5 A	Speed	1750 rpm
Service Factor	1.15	Phase	3
Efficiency	85.5 %	Duty	Continuous
Insulation Class	F	Design Code	B
KVA Code	N	Frame	56C
Enclosure	Totally Enclosed Fan Cooled	Overload Protector	No
Ambient Temperature	40 °C	Drive End Bearing Size	6205
Opp Drive End Bearing Size	6205	UL	Recognized
CSA	Y	CE	Y
IP Code	55		

Technical Specifications

Electrical Type	Squirrel Cage Inverter Rated	Starting Method	Line Or Inverter
Poles	4	Rotation	Reversible
Mounting	Round	Motor Orientation	Horizontal
Drive End Bearing	Ball	Opp Drive End Bearing	Ball
Frame Material	Stainless Steel	Shaft Type	T
Overall Length	13.77 in	Shaft Diameter	0.625 in
Shaft Extension	2.06 in	Assembly/Box Mounting	F1 Only
Outline Drawing	16992600ME	Connection Diagram	00501001ME

This is an uncontrolled document once printed or downloaded and is subject to change without notice. Date Created: 06/29/2018

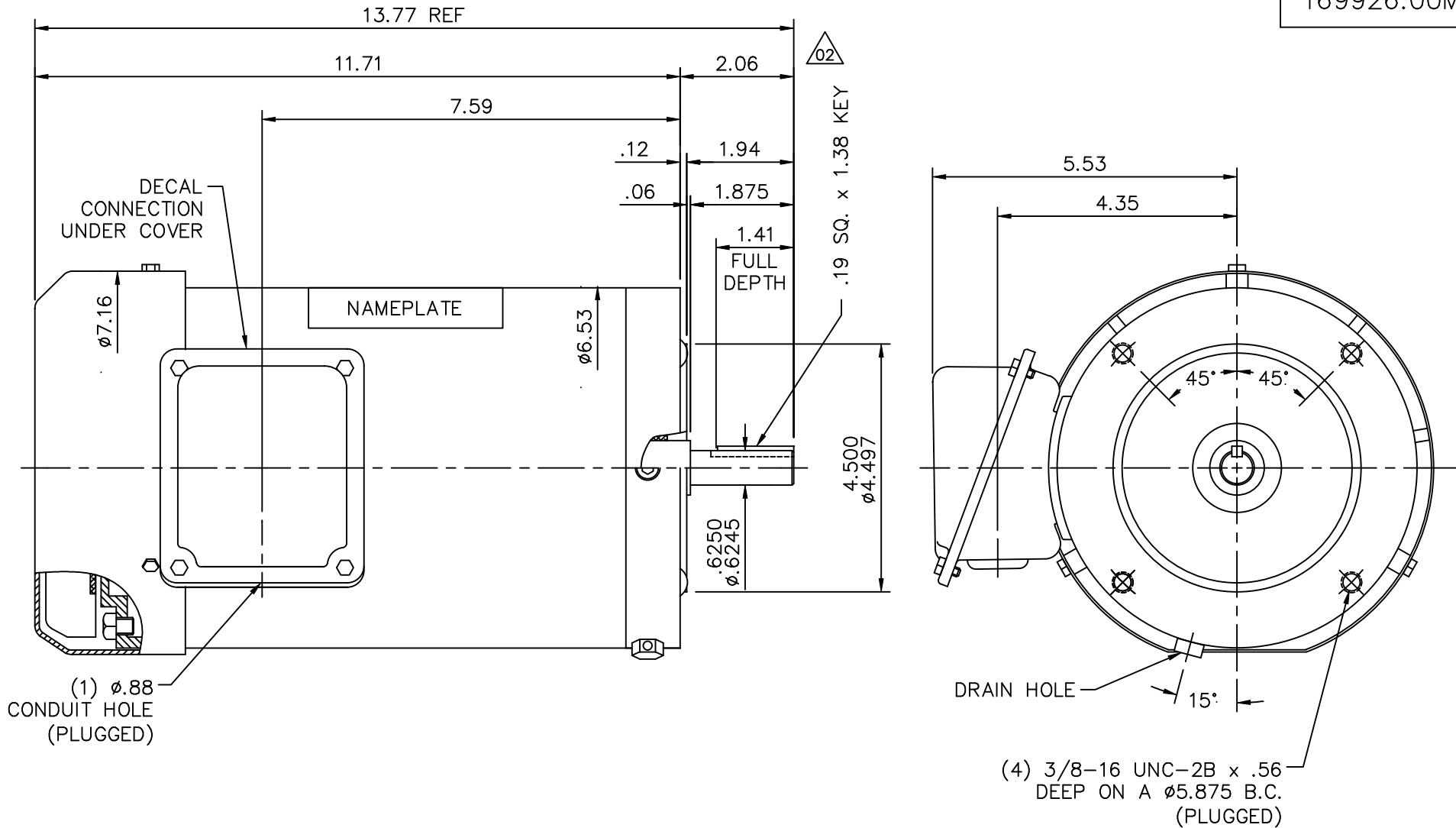

MAXIMUM FACE RUNOUT TO BE .004 T.I.R.
 MAXIMUM PILOT ECCENTRICITY .004 T.I.R.
 PERMISSIBLE SHAFT RUNOUT .002 T.I.R.

GASKETS THROUGHOUT

				TOLERANCES UNLESS SPECIFIED		MARATHON ELECTRIC	DRAWN MGM 04/09/03		
				DEC.	INCHES		CHK	RDW 04/09/03	
				.X	±.1	TITLE OUTLINE - 56C FRAME TEFC - "C" FACE	APPD	SCALE 3=8	
				.XX	±.03		REF		
02	UPDATED SHAFT EXT DIMS	RDW 4/26/04	SW .XXX	±.005	MAT'L.		FMF		
01	CONDUIT HOLE WAS 1/2-14 NPT, DIM .157 WAS .12	SW 10/7/2003	RDW .XXXX	±.0005	FINISH	PREV			
NO.	REVISION	BY & DATE	CHK	ANG	±1/2'				
THIS DRAWING IN DESIGN AND DETAIL IS OUR PROPERTY AND MUST NOT BE USED EXCEPT IN CONNECTION WITH OUR WORK ALL RIGHTS OF DESIGN AND INVENTION ARE RESERVED THIS IS AN ELECTRONICALLY GENERATED DOCUMENT - DO NOT SCALE THIS PRINT				RFP	CAD FILE	16992600ME	SIZE	DRAWING NO.	REV.
				DIST	A	169926.00ME	01		

VIEW FROM OUTSIDE OF MOTOR AT SWITCH END.



VOLTAGE	L1	L2	L3	JOIN & INSULATE
HIGH	T1	T2	T3	(T4,T7) (T5,T8) (T6,T9)
LOW	T1,T7	T2,T8	T3,T9	T4,T5,T6

TOLERANCES UNLESS SPECIFIED		DRAWN RDW 04/12/02		MARATHON ELECTRIC		CHK		
DEC.	INCHES			TITLE		APPD		
.X	±.1			EXTERNAL WIRING DIAGRAM 3 PHASE W/O PROTECTOR		SCALE 1=1		
.XX	±.01			MAT'L. DECAL - 004014		REF FIG.2-51		
.XXX	±.005			FINISH		FMF		
.XXXX	±.0005			NO. REVISION		PREV		
		BY & DATE	CHK	ANG	±1/2'			
THIS DRAWING IN DESIGN AND DETAIL IS OUR PROPERTY AND MUST NOT BE USED EXCEPT IN CONNECTION WITH OUR WORK ALL RIGHTS OF DESIGN AND INVENTION ARE RESERVED THIS IS AN ELECTRONICALLY GENERATED DOCUMENT - DO NOT SCALE THIS PRINT		RFP	04/12/02	CAD FILE	00501001ME	SIZE	DRAWING NO.	REV.
		DIST				A	005010-01ME	

